

SWISS MADE

Alulineartechnik AG

ALUMINIUM RAIL GUIDES

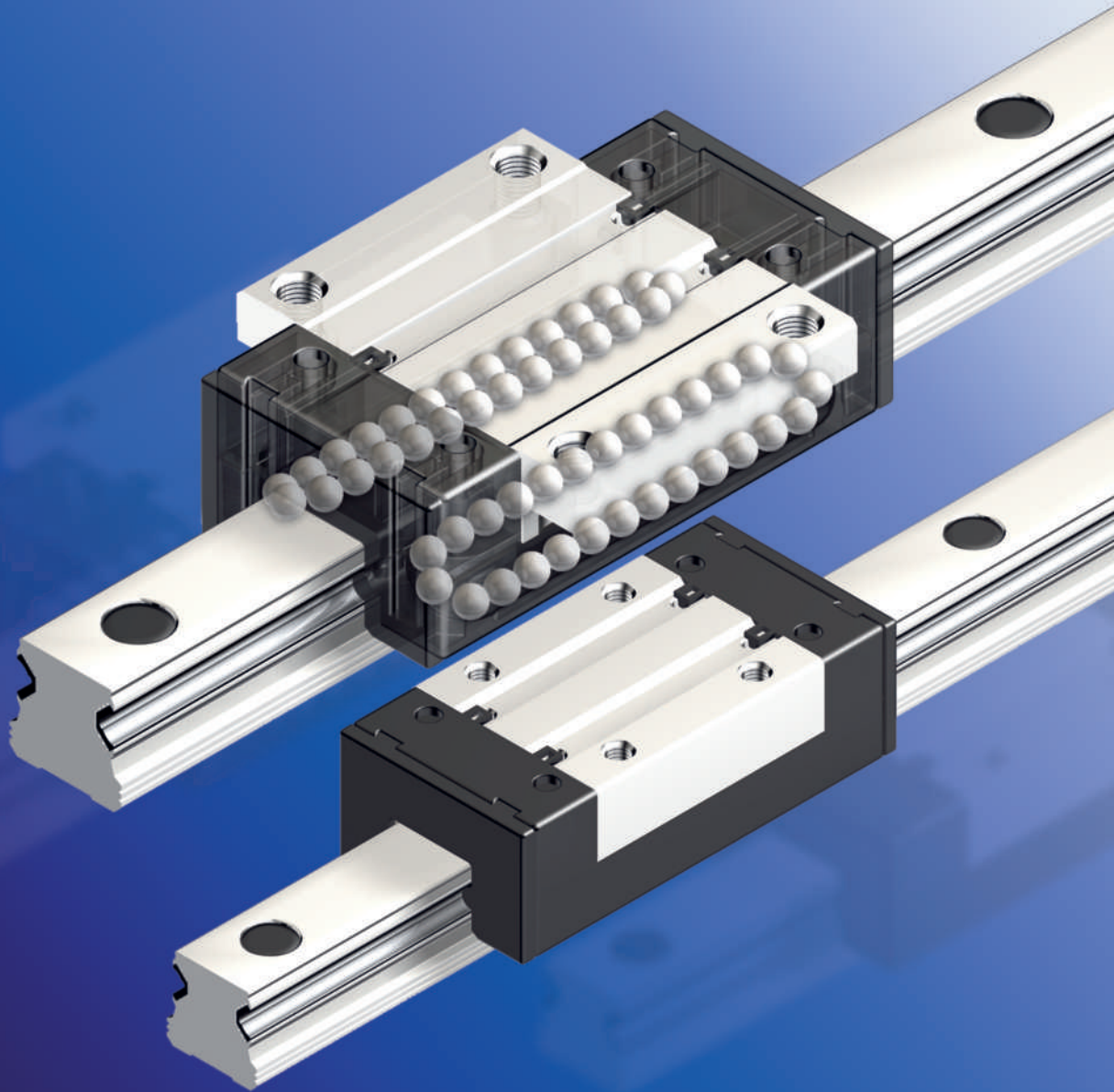

LIGHTWEIGHT



STAINLESS



INTERCHANGEABLE

Alulin

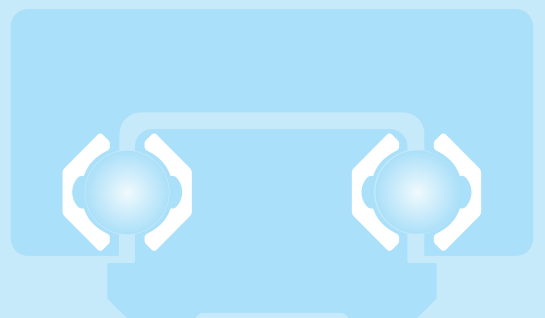

© Copyright by Alulineartechnik AG

The contents of this publication are the copyright of the publisher and may not be reproduced (even extracts) unless prior written permission is granted.

Every care has been taken to ensure the accuracy of the information contained this publication but no liability can be accepted for any loss or damage weather direct, indirect or consequential arising out of use of the information contained herein.

Specifications are subject to change without notice and without any obligation on the part of the manufacturer.

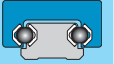

Generals		Page
Introduction	4
Accuracy	5
Mounting	6
Dimensioning	7
Lubrication Concept	8
Measure Scale		
Runner Block Flange	9
Runner Block Standard, high	10
Aluminium Rail Guide with Niro Steel reinforcement	11
Accessories		
Seal Unit	12
Lube Units with sealing function	12
Lubricating Nipple	13
Hydraulic-type lube nipple	13



Introduction

Product Overview

Alulin accurate profile rails and ball bearing runner blocks are designed especially for all sorts of linear movements and are therefore suitable for use in most type of machinery. The rails consist of wrought aluminium having two pressed-in hardened stainless steel shafts serving as the raceways for the balls of the runner blocks. Advantages are the light weight and corrosive resistant materials. Fixing holes in the attachment surfaces enable machine parts to be directly mounted onto the runner blocks. With this combination it is possible for us to offer a guide system which achieves a good price/performance ratio.

Product Range

- There are two versions of our carriages: Flange and a high and small one
- There are two accuracies for our carriages: Standard precision (0) and a high precision called "P" in our catalogue
- The guide rails are only in the higher precision "P" available
- The guide system is classified after the carriage accuracy
- The standard carriage is not preloaded, can be ordered separately and is available from stock (interchangeable)
- The precision guide "P" is just as preloaded and as system together with the rail (in pair) available
- The loading rate is based on a service performance of 100 km

Advantages

- Compact, light-weight design with a weight saving of 60% versus steel versions.
- Same connection dimensions as steel ball rail systems.
- Much greater parallelism and height offsets of mounting bases possible.
- Insensitive in an aggressive environment (dust, shavings)
- Significantly better corrosion resistance in comparison with the steel versions.
- Runner blocks initially greased in-factory, therefore provided with long-term lubrication.
- Due to ball retainers in the runner blocks, runner blocks can be removed from the rail without any loss of balls.
- Complete interchangeability between runner blocks and rails (not preloaded).
- Both sides of rail are reference edges. The runner block has one reference edge, which can be verified by turning it on the rail.

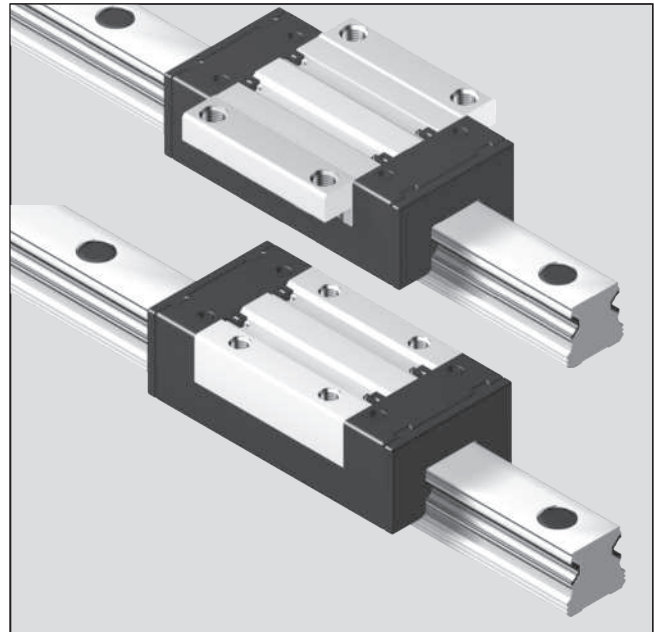

Application Range

Speed	v_{max}	=	2 m/s
Acceleration	a_{max}	=	30 m/s²
Temperature	T	=	0°- 60° C

Application

If you look at the top standing limits, you will see that a broad area of applications is opening. Especially in light machinery, handling technology, jigs and fixtures, assembly technology, manual displacement systems, machine enclosures, door – and window technology, booth- and store construction and many more.

Our rail guides cannot be used in:

- Main axis of a CNC or tooling machine
- Aggressive dusts
- Oscillating conveyor
- Danger of life or physical condition (for example unsecured overhead installation)



Accuracy

The carriage and the rails are in the ball area produced with high precision, that not preloaded carriages can be replaced by another anytime.

The following values are valid for the stocked types in the measure scale from page 9 and 10.

Height tolerance “H”

The height tolerance of several carriages on a rail is maximal $\pm 30 \mu\text{m}$ (precision class “P”: $\pm 15 \mu\text{m}$). In any order of several carriages and rails is the maximum $\pm 120 \mu\text{m}$ (precision class “P”: $\pm 40 \mu\text{m}$).

Side tolerance “D”

The side tolerance of several carriages on a rail is maximal $\pm 30 \mu\text{m}$ (precision class “P”: $\pm 15 \mu\text{m}$). In any order of several carriages and rails is the maximum $\pm 70 \mu\text{m}$ (precision class “P”: $\pm 40 \mu\text{m}$).

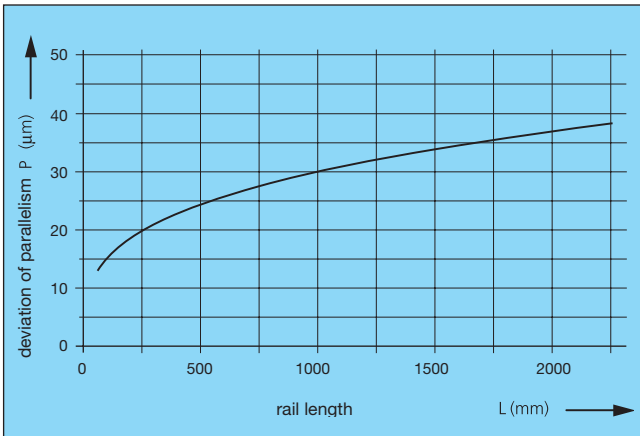
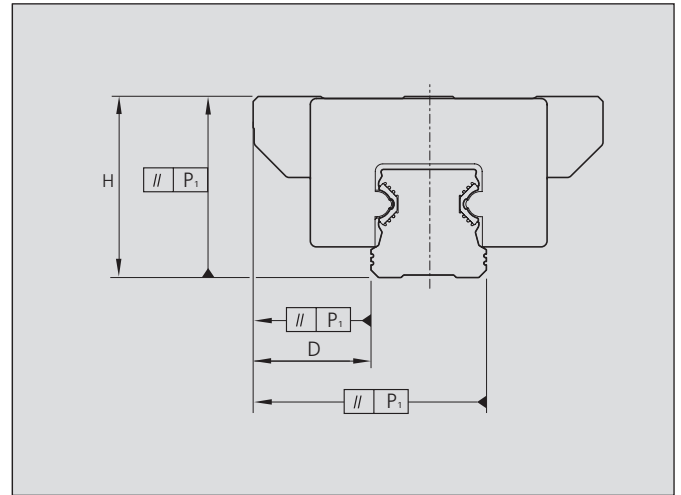

Deviation of parallelism

Deviation of parallelism can be found in the diagram on the left.

Using the precision carriages the curve shifts down and all values improve by approximately 20%.

Carriages in standard precision (stocked products)

For normal applications we recommend a combination of carriage and rail without preload. With the standard precision it will have a tolerance of μm between the rail and carriage. It is possible to order just the rail or carriage separately (interchangeable and in stock).

An example for a runner block flange without preload: FNS-1500.

Runner blocks in high precision and preloaded

For more precision applications, the carriage will be made (in the name “P”) with even tighter tolerances.

These carriages are just made with preload (V) and are in combination with the rail (in pair) available.

The order number for high, narrow carriages is for example GNS-15PV.



General Mounting Instructions

Parallelism

Parallelism of the installed rails measured at the guide rails and the runner blocks.

The parallelism offset P1 causes a slight increase in preload on one side of the assembly.

As long as values specified in the table are met, the effect of parallelism offsets on the service life can generally be neglected. Through the deviation in parallelism (P1) the preload is increased on one side. If table values are adhered to, the influence on the service life is generally negligible. Profiled rail system allow substantially higher installation tolerances compared to steel rail systems.

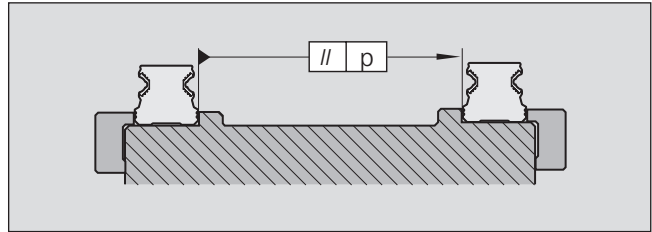

Size	Permissible deviation in parallelism p_{max}	
	Standard	Preload
15	0,027	0,018
20	0,031	0,021
25	0,034	0,022

Values in mm

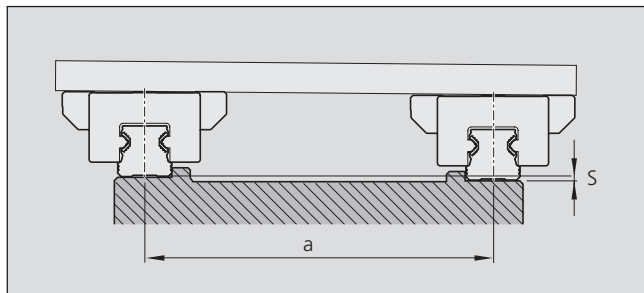

Height deviation

Given adherence to the permissible height deviation "S", the influence on the service life can generally be neglected.

Permissible height deviation in lateral direction "S"

Calculation factor	Standard	Preload
f	$1,2 \cdot 10^{-3}$	$0,75 \cdot 10^{-3}$

$S \leq a \cdot f$	S = Permissible height deviation (mm)
	a = Distance between rails (mm)
	f = Calculation factor

Permissible height deviation in longitudinal direction

Given adherence to the permissible height deviation "R", the influence on the service life can generally be neglected.

Permissible height deviation in longitudinal direction "R"

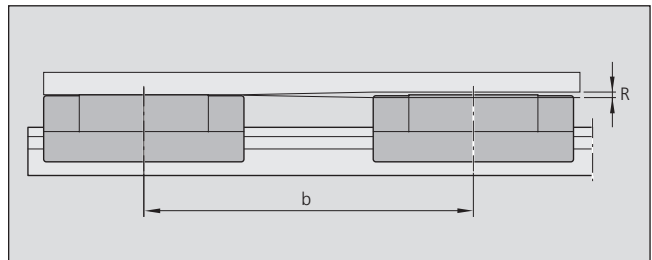

$R \leq b \cdot g$	R = Permissible height deviation (mm)
	b = Distance between runner blocks (mm)
	g = Calculation factor

Calculation factor	Standard	Preload
g	$6 \cdot 10^{-4}$	$2,1 \cdot 10^{-4}$



Determination of the carriage size

1. Pre-select the runner block
2. Determine F_{comb}
3. Calculate the ratio of the dynamic load capacity “C” of the selected runner block relative to F_{comb} (F_{comb} divided by “C”)

If $F_{comb} / C > 0.4$: runner block is sized too small. Select the next largest size and repeat the calculation (step 2 and 3).

The ratio must always be $F_{comb} / C \leq 0.4$, otherwise F_{max} will be exceeded.

Note:

The load ratio F_{comb} / C is the quotient of the equivalent dynamic load on the bearing divided by the dynamic load capacity “C”.

Please control dynamic demand of bolted joints.

Calculation of load on bearing for a runner block

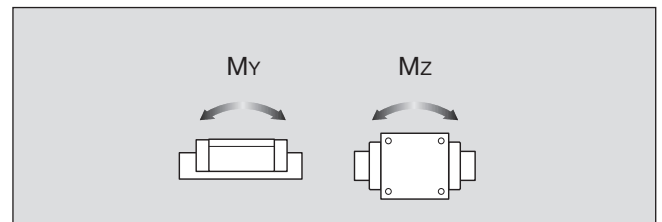
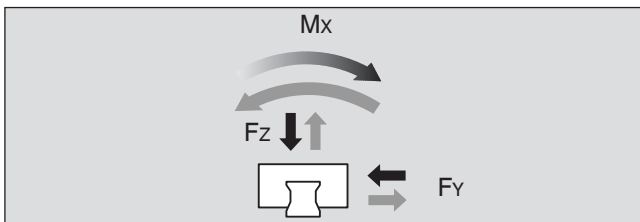

F_{comb}	=	combined equivalent load	(N)
F_y, F_z	=	Dynamic load	(N)
M_x	=	torque of the X-axis ¹⁾	(Nm)
M_y	=	torque of the Y-axis ²⁾	(Nm)
M_z	=	Moment um die Z-Achse ²⁾	(Nm)
M_t	=	dynamic torsional moment load capacity	(Nm)
M_L	=	dynamic longitudinal moment load capacity	(Nm)
C	=	dynamic load capacity	(N)
b	=	operating factors	

- 1) Torque M_x will only be fully effective in an application with one guide rail.
- 2) Torque M_y or M_x will only be fully effective when only one runner block is mounted on one guide rail.

For values, see runner block on page 9 and 10
 For values, see runner block on page 9 and 10
 For values, see runner block on page 9 and 10
 For values, see table “Recommended values for operating factors “b””.

$$F_{comb} = b \cdot (|F_z| + |F_y| + C \cdot \frac{|M_x|}{M_t} + C \cdot \frac{|M_y|}{M_L} + C \cdot \frac{|M_z|}{M_L})$$

Recommended operating factors b

Values for operating factors b

- | | |
|-----|--|
| 1,0 | Clean environment, low technical demands, manual operation |
| 1,5 | In a linear motion axis with ball screw drive |
| 2,0 | Linear motion axis with toothed belt drive |
| 6,0 | Linear motion axis with pneumatic drive |
| 9,0 | In very dirty environments |

Static load rating

A static load rating could not specify, because of the composite material. Instead of this you can find the values F_{max} respectively M_{max} , when it exceed it may cause malfunction.



Lubrication Concept

We aim to achieve a lifetime lubrication, which we define as at least 30'000km. The following conditions apply:

- Initial greasing with Dynalub 510
- Mounted seal unit
- No exposure to metal-working fluids
- Ambient temperature $T = 20^{\circ}$ to 30°C

First, the quotient F_{comb} / C is calculated with F_{comb} according to the formula on the previous page and the dynamic load rating C from the mass tables on pages 9 and 10. With this value you go then in to the diagram below.

Is $F_{\text{comb}} / C \leq 0,15$, it lies in the zone A of the diagram below. This means it will have lifetime lubrication.

With $0,15 < F_{\text{comb}} / C \leq 0,4$ it lies in the zone B of the diagram below.

For this you must distinguish two cases:

For Example $F_{\text{comb}} / C = 0,25$ goes up to 6400km.

- Is the running distance required < 6400 km, there is a lifetime lubrication here.
- Is the running distance required > 6400 km, then instead of seal unit the lube unit with sealing function must be used.

Value $F_{\text{comb}} / C > 0,4$ then F_{max} is exceeded.

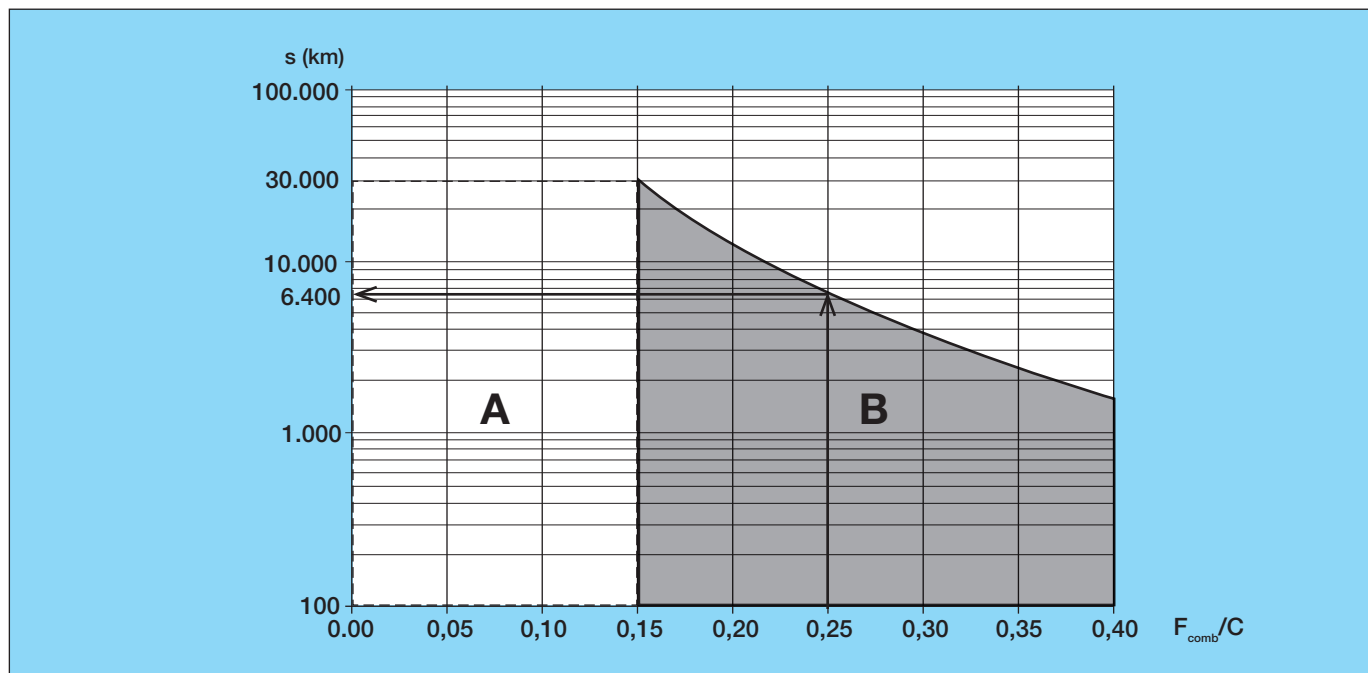

Note:

- Take account of the general service life of lubricants.
- If other lubricants are used, this may lead to a reduction in the re-lubrication intervals, the achievable travel in short-stroke applications and the load capacities. Possible chemical interactions between the plastic materials, lubricants and preservative oils must also be taken into account.
- Do not use greases with solid particles such as graphite or MoS_2 .
- If your application involves more demanding environmental requirements such as clean room, vacuum, food industry, increased exposure to fluids or aggressive media, extreme temperatures, please consult us. These situations must be investigated on a case by case basis and may require the use of a special lubricant. Be sure to have all the information concerning your application at hand when contacting us.

Flanged Ball Runner Block



This light-weight aluminium runner block is designed for cost-effective applications such as assembly and handling processes. Mounting dimensions are identical to those of the steel guiding rails and in accordance to DIN 645-1, which makes them interchangeable and replaceable.

The runner block has a lateral abutment edge and can then be screwed from above or below. Runner block consists of wrought aluminium alloy with a tensile strength of 350N/mm², balls and running tracks of hardened anti-friction bearing steel. All others parts are made of POM. The carriage is pre-lubricated and has standard according seal units, which you can replace.

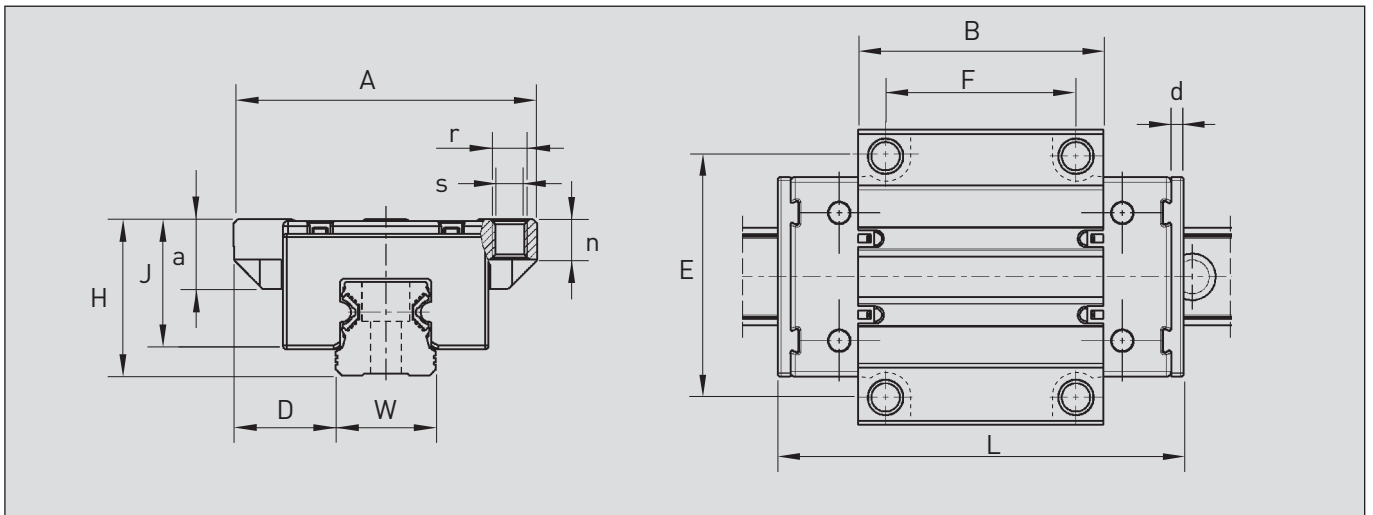
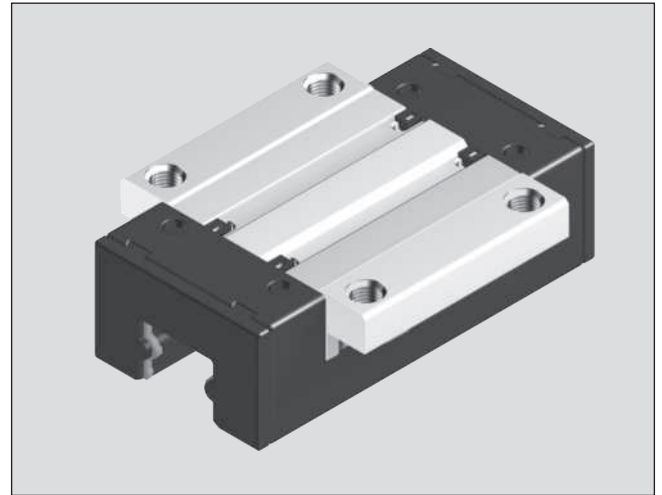

Order ref. no.	A	H	W	D	L	B	E	F	s	r	n	J	a _{max}	d	weight (kg)
FNS-1500	47	24	15	16,0	64,0	37,8	38	30	4,3	M5	6,0	19,8	11	2,5	0,08
FNS-2000	63	30	20	21,5	85,9	51,5	53	40	5,3	M6	8,0	24,7	13	2,8	0,18
FNS-2500	70	36	23	23,5	96,0	58,0	57	45	6,7	M8	9,3	29,9	17	3,0	0,26

Size	Dynamic load capacities (N) ¹⁾		Torque (Nm)			
	C _{dyn.}	F _{max} ²⁾	M _t _{dyn.}	M _{t,max} ²⁾ _{stat.}	M _L _{dyn.}	M _{L,max} ²⁾ _{stat.}
15	5 000	2 000	36	14	29	12
20	11 000	4 400	101	40	89	35
25	16 000	6 400	165	66	147	59

¹⁾ Determination of the dynamic load capacities and torques is based on a travel life of 100.000 m.

²⁾ Due to the mechanical operations of guide rails and runner block with their different materials, is not possible to, clearly indicate a load rating. In this case never exceed F_{max} or M_{max}. Otherwise malfunction or damage may occur.



Standard Runner Block

This light-weight standard runner block corresponds to the structure of the flanged runner block from the previous page. It's only slimmer and designed for mounting from above.

The mounting dimensions are also identical to the steel guiding rails and in accordance to DIN 645-1. On this way you can easily change the installed constructions.

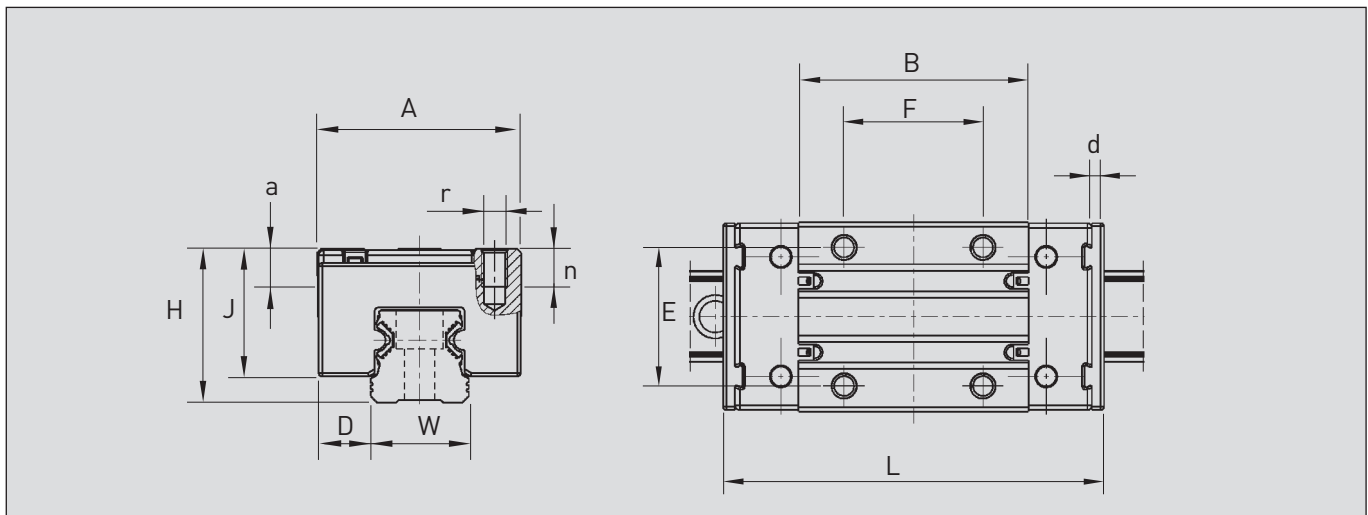
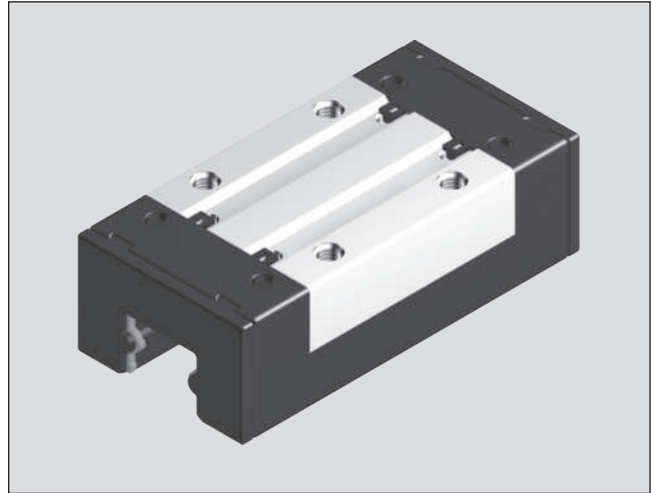

Order ref. no.	A	H	W	D	L	B	E	F	r	n	J	a	d	weight (kg)
GNS-1500	34	24	15	9,5	64,0	37,8	26	26	M4	6,0	19,8	4,1	2,5	0,07
GNS-2000	44	30	20	12,0	85,9	51,5	32	36	M5	7,5	24,7	5,5	2,8	0,15
GNS-2500	48	36	23	12,5	96,0	58,0	35	35	M6	9,0	29,9	6,4	3,0	0,22

Size	Dynamic load capacities (N) ¹⁾		Torque (Nm)			
	C dyn.	$F_{max}^{2)}$	M_t dyn.	$M_{t,max}^{2)}$ stat.	M_L dyn.	$M_{L,max}^{2)}$ stat.
15	5 000	2 000	36	14	29	12
20	11 000	4 400	101	40	89	35
25	16 000	6 400	165	66	147	59

¹⁾ Determination of the dynamic load capacities and torques is based on a travel life of 100.000 m.

²⁾ Due to the mechanical operations of guide rails and runner block with their different materials, is not possible to, clearly indicate a load rating. In this case never exceed F_{max} or M_{max} . Otherwise malfunction or damage may occur.

Corrosion Resistant Profiled Rail



The aluminium profile rails are made of high quality aluminium alloy with rolled and precisely calibrated raceways made of stainless steel (niro-steel) and are produced only in the accuracy class P.

The use of aluminium achieves a weight saving compared to the steel types. It better compensates any unevenness in the mounting surface. The use of stainless steel for the track material, makes the rail corrosion resistant. The rail with the order number **A..-....** is for mounting from above and **B..-....** for mounting from below. Because of the aluminium / steel composite construction, the rails should get ordered in the right length. Only in exceptional cases it is allowed to cut it by yourself.

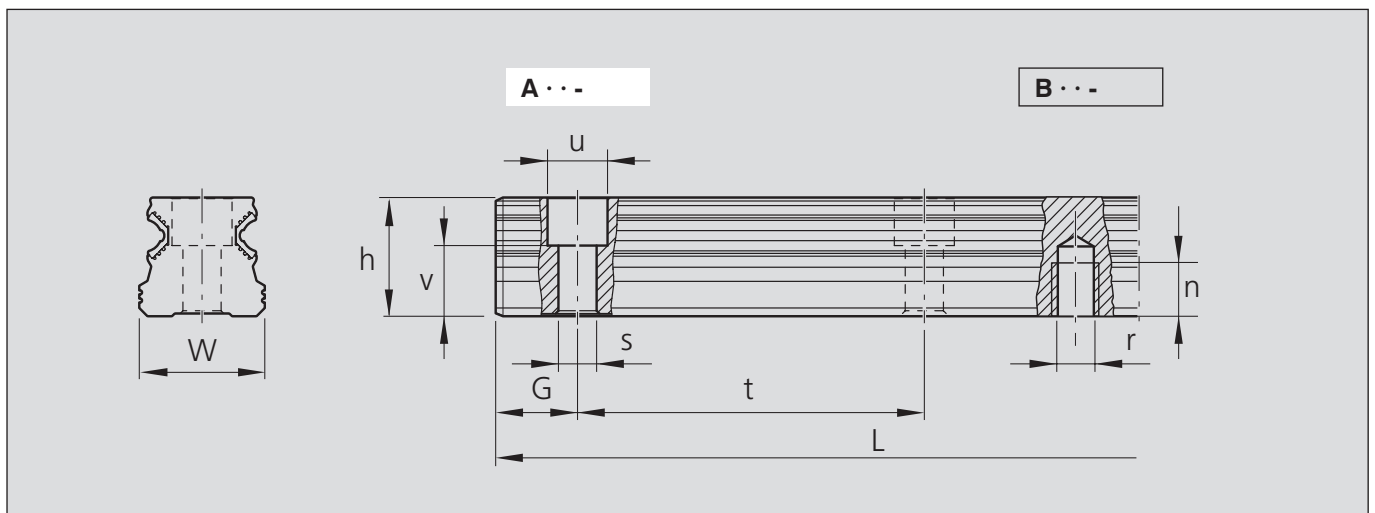
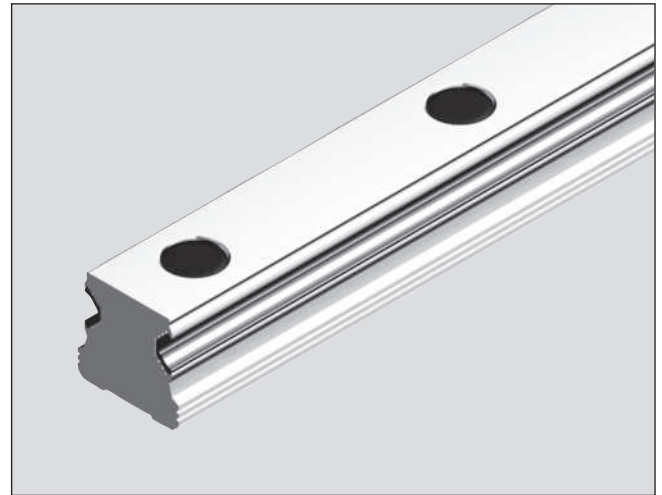

Order ref. no.	W	h	u	v	s	G*	r	n	t	L _{max}	weight kg/m
A15-....	15	14,0	7,5	8,1	4,4	28			60	4000	0,57
B15-....	15	14,0				28	M5	7	60	4000	0,57
A20-....	20	19,0	9,5	11,6	6,0	28			60	4000	0,98
B20-....	20	19,0				28	M6	9	60	4000	0,98
A25-....	23	21,8	11,0	12,9	7,0	28			60	4000	1,25
B25-....	23	21,8				28	M6	12	60	4000	1,25

Mounting caps ¹⁾
oSP-315
oSP-320
oSP-325

* recommended G-measure

→ Please insert rail lengths in mm.

¹⁾ Please order separately



Accessories

Seal Unit

- All runner blocks are delivered with greased seal units.
- The basic material is POM

Instructions for the replacement

- Assembly with mounted carriage is not possible.
- Pull exchanged seal unit up
- Insert the new seal unit
- Push the runner block back on the guide rail.
The seal unit align vertical to the guide rail.

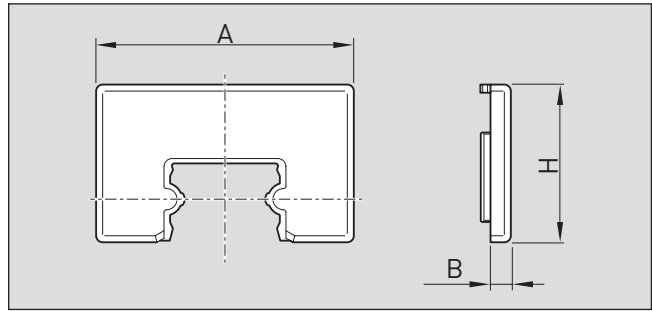

Order ref. no.	Measurements (mm)		
	A	B	H
nVA-1500	31,7	2,5	19,4
nVA-2000	43,2	2,8	24,3
nVA-2500	47,2	3,0	26,5

Lube unit with sealing function

Lube units with sealing function are used for applications with higher mileage or dirty environment. The in its interior located, with oil ISO VG 100 impregnated foam, allows a contentions lubrication and simultaneously acts as a front seal. Because of this a service life of 12500 km is possible, without further lubrication. After that you can lubricate via the lubrication oil connections or the enclosed grease nipple. Optimally is when you replace the whole unit.

The lube units are simply pushed over the rail and mounted by the attached bayonet fittings at the front side of the runner block, when the existing seal unit is removed.

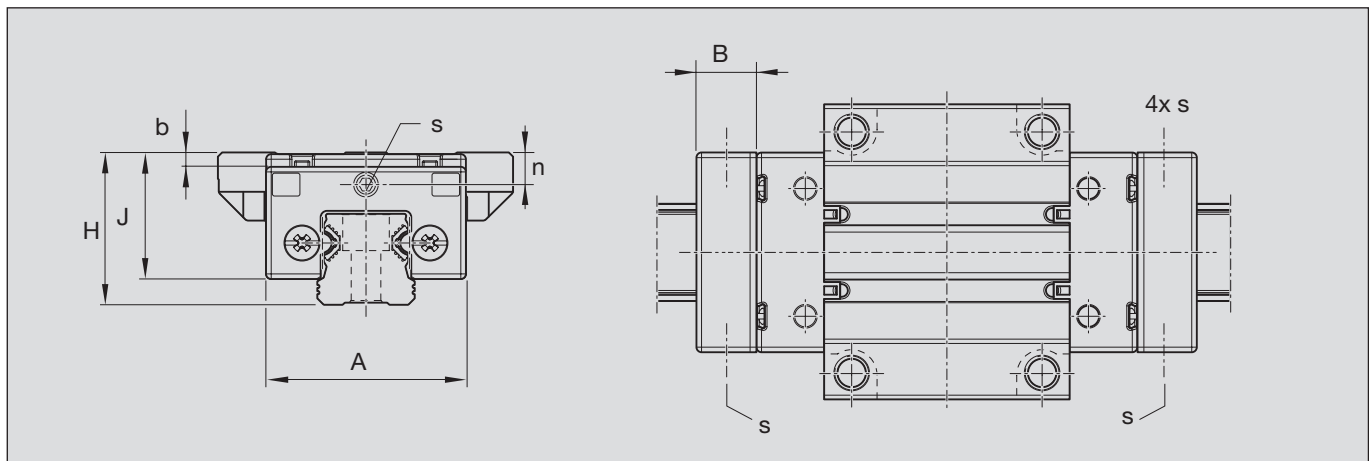

Order ref. no.	Size	A	B	H	J	b	n	s	oil (cm ³)	supplied grease nipple
dSF-1500	15	31,7	11,5	24	19,4	0,4	4,5	M3	0,65	nSN-00M3
dSF-2000	20	43,2	13,0	30	24,3	0,4	5,0	M6	1,35	nGN-00M6
dSF-2500	23	47,2	14,0	36	30,0	3,4	7,6	M6	1,70	nGN-00M6



Lubricating nipple for lube units

Funnel-type lube nipple
for size 15

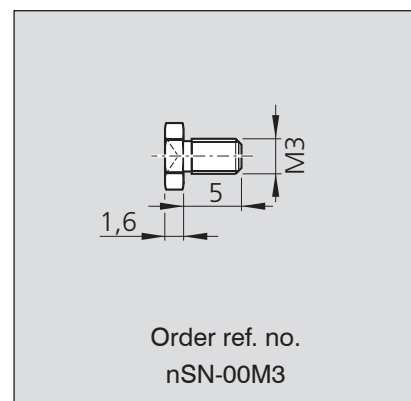
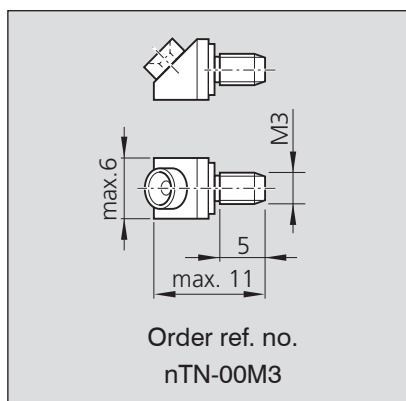

Hydraulic-type lube nipple
for sizes 20 and 25

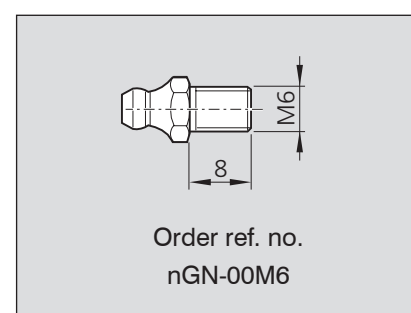
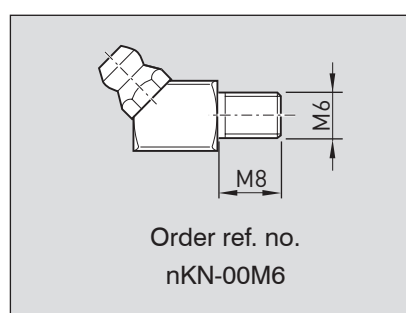

Manual clamping unit

The manual clamping unit dHK is made of aluminium and plastic. It fits on both type of rails (A and B).

A.....

B.....

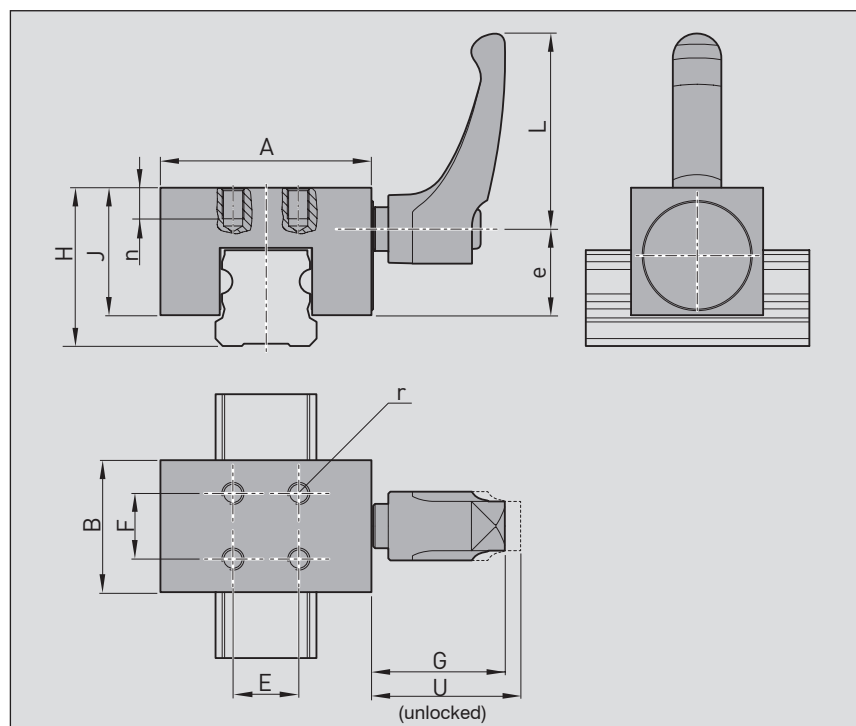

Order ref. no.	Torsional	Measurements (mm)											
		A	B	e	H	J	E	F	L	G	U	n	r
dHK-1500	130 N / 3 Nm	34	20	12,9	24	19,8	10	10	40	29,9	33,3	6	M3
dHK-2000	250 N / 3 Nm	44	24	16,0	30	24,0	12	12	40	29,9	33,4	6	M4
dHK-2500	330 N / 3 Nm	48	30	19,6	36	29,0	15	15	44	29,8	33,3	7	M5



Alulineartechnik and the brand Alulin® – the world's only manufacturer of rail guides in aluminium with stainless steel insert – Swiss quality



07 14

ALULINEARTECHNIK AG

**Schaffhauserstr. 96
CH-8222 Beringen**

Telefon: +41 (0) 52 682 1686

Telefax: +41 (0) 52 682 1774

Mail: info@alulineartechnik.ch

Web: www.alulineartechnik.ch

Your Distributor